

GLOBE VALVE 501T DIRECT ACTION

*1 AIR EXHAUST POSITION FOR $\phi 218$ & $\phi 270$.
 *2 AIR EXHAUST POSITION FOR $\phi 350$ & $\phi 450$.

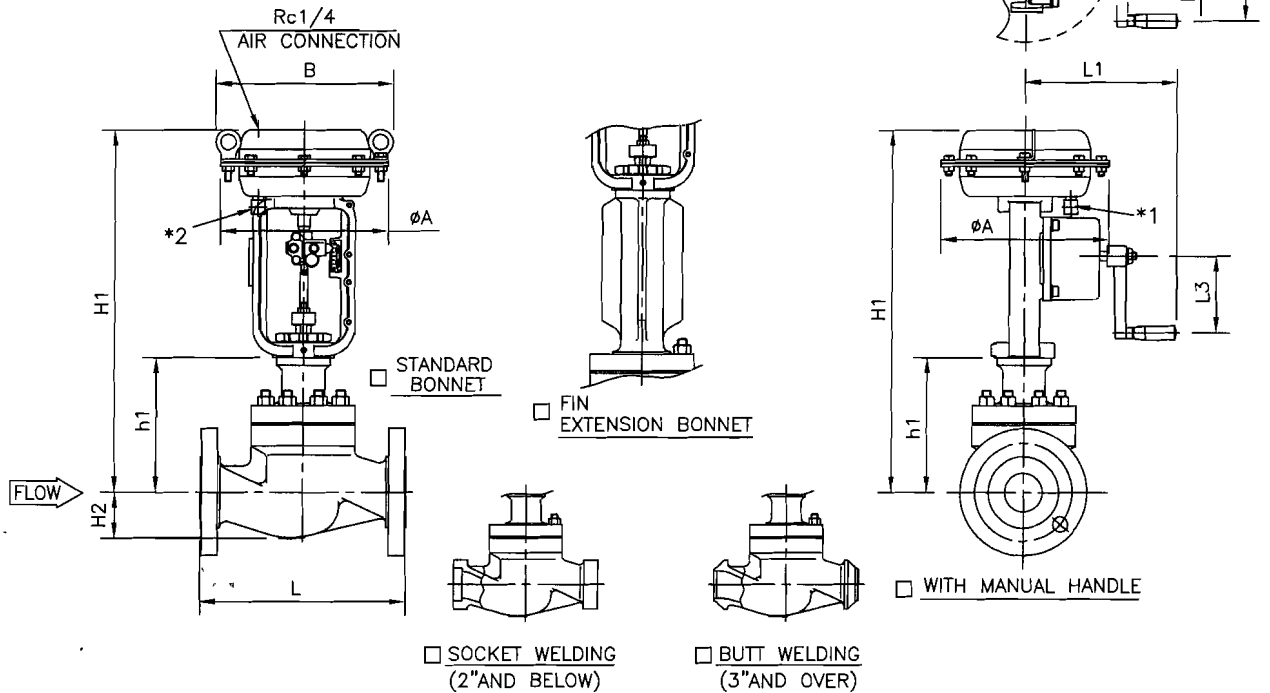

DIMENSIONS

UNIT : mm

VALVE SIZE	FACE TO FACE : L								H2	STANDARD BONNET		FIN EXTENSION BONNET		ACTUATOR					CODE NO.
	ANSI 150# RF		ANSI 300# RF		ANSI 600# RF		ANSI 300# SW			ANSI 600# SW		SIZE	WITH MANUAL HANDLE						
	JIS 150# RF	JIS 300# RF	JIS 600# RF	ANSI 300# BW	ANSI 600# BW	ANSI 300# RTJ	ANSI 600# RTJ	A		B	L1		L3	L4					
90 $\frac{1}{2}$ " (15A)	184	194	206	206	206	206	206	206	32	129	430 525 560	229	530 625 660	\square 218 \square 270 \square 350	231 283 367	196 230 230	65 100 100	18.5 27.5 27.5	5221LA 5227LA 5235LA
91 $\frac{3}{4}$ " (20A)	184	194	206	206	206	206	206	206	32	129	430 525 560	229	530 625 660	\square 218 \square 270 \square 350	231 283 367	196 230 230	65 100 100	18.5 27.5 27.5	5221LA 5227LA 5235LA
01 1" (25A)	184	197	210	210	210	210	210	210	36	129	430 525 560	229	530 625 660	\square 218 \square 270 \square 350	231 283 367	196 230 230	65 100 100	18.5 27.5 27.5	5221LA 5227LA 5235LA
93 $1\frac{1}{2}$ " (40A)	222	235	251	251	248	251	251	251	58	175	475 570 605 670	325	625 720 755 820	\square 218 \square 270 \square 350 \square 450	231 283 367 472	196 230 230 336	65 100 100 160	18.5 27.5 27.5 32	5221LA 5227LA 5235LA 524SLA
02 2" (50A)	254	267	286	286	283	286	289	289	62	175	475 570 605 670	325	625 720 755 820	\square 218 \square 270 \square 350 \square 450	231 283 367 472	196 230 230 336	65 100 100 160	18.5 27.5 27.5 32	5221LA 5227LA 5235LA 524SLA
94 $2\frac{1}{2}$ " (65A)	276	292	311	311	308	311	314	314	75	200	595 630 695	350	745 780 845	\square 270 \square 350 \square 450	283 367 472	230 230 336	100 100 160	27.5 27.5 32	5227LA 5235LA 524SLA
03 3" (80A)	298	317	337	337	333	337	340	340	85	200	595 630 695	350	745 780 845	\square 270 \square 350 \square 450	283 367 472	230 230 336	100 100 160	27.5 27.5 32	5227LA 5235LA 524SLA
04 4" (100A)	352	368	394	368	384	394	397	397	105	245	675 740	395	825 890	\square 350 \square 450	367 472	230 336	100 160	27.5 32	5235LA 524SLA

* FLANGE IS ACCORDING TO THE STANDARD WHICH IS DESCRIBED ON SPECIFICATION SHEET.

NOTE:

DRAWING No.

E-501T-5200LA-D-N
S

REV.

G

KOSO