



Pekos[®]
V A L V E S



Pekos Valves group structure

Manufacturing

Pekos valves, S.A. has been designing and manufacturing ball valves under Pekos® brand name since 1988, catering for a wide range of different industries such as shipbuilding, petrochemical, oil and gas, energy, power plants, chemical...



Certificates / R+D

Bilbao (Spain), where we develop our production: machining, assembling, testing and R+D.

Sales / Marketing

Montmeló - Barcelona (Spain), sales and headquarters with a state of the art warehouse, location of all sales, marketing and logistic activities. Our logistics, refined throughout all these years in the market, allows us to supply our products with short delivery times. The fully automatic warehouses in Barcelona and Bilbao reduce the preparation time of our customers' orders and guarantee their accuracy.



Pekos Valves company philosophy

To bring to the market standard and special execution ball valves with short lead times, at competitive price and most importantly long service life. This is combined with dedicated sale and after-sale service by a truly international team.



Company profile

Group founded in 1988
 Capital + reserves: 2.500.000 €
 Sales headquarters and production facilities: 85.000 m²
 Staff: 130
 Production capacity: 15.000 valves per month
 Turnover 2014: 50.000.000 €
 President: Angel Arranz



Pekos Valves stocks on line

At www.pekos.es all our distributors can check, on line, stock availability, more than 50.000 valves in different materials and configurations, more than 20 million € stock at your service.







DIN

Ball valves

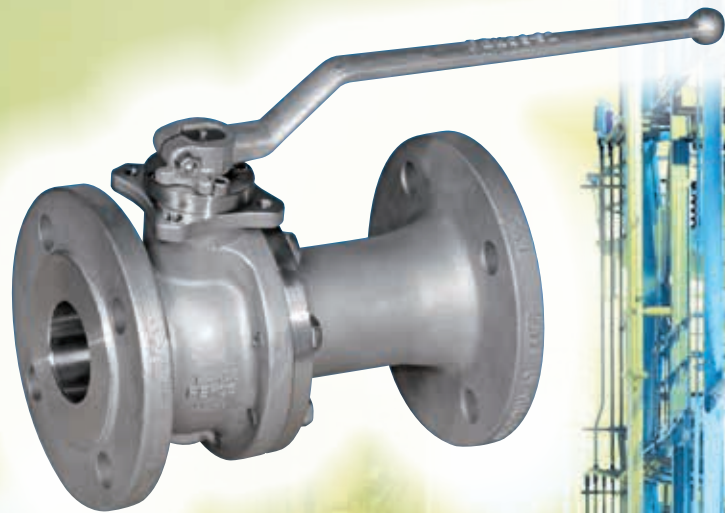



Floating ball

General features

- Split Body
- Full bore
- Soft seat
- Bidirectional
- Antistatic stem
- Anti blow out stem
- Autoadjustable packing
- Self cavity pressure relief
- Fire safe
- Low emission design

Standards

- Top flange ISO 5211
- Flanges EN 1092-01
- Face to face EN 558 series 1, 14 and 15 (former F1, F4 and F5)
- Testing EN 12266, ISO 5208
- Design EN 12516, ISO 17292
- Fire Safe API 607, ISO 10497

Approvals

- PED 97/23/CE
- FIRE SAFE
- TA-LUFT
- ISO 15848
- ATEX (94/9/CE)
- TÜV AD- 2000 Merkblatt A4
- SIL (ICE 61508)
- EN 161/264
- DVGW - EN 13774

- DN 15 - 125 / PN 40
- DN 15 - 150 / PN 25
- DN 15 - 200 / PN 10 - 16

Standard construction materials

Description	Material	
	Carbon steel	Stainless steel
Body	1.0619	1.4408
Ball	1.4408	1.4408
Seats	PTFE	PTFE
Stem	1.4401	1.4401
Stem packing	PTFE + Graphite	PTFE + Graphite
Body seal 1	PTFE	PTFE
Body seal 2	Graphite	Graphite

Other materials, upon request.





Guided ball

General features

- Split body
- Full bore
- Soft seat
- Bidirectional
- Antistatic stem
- Anti blow out stem
- Autoadjustable packing
- Self cavity pressure relief
- Fire safe
- Low emission design

Standards

- Top flange ISO 5211
- Flanges EN 1092-01
- Face to face EN 558 serie 15 (former F5)
- Testing EN 12266, ISO 5208
- Design EN 12516, ISO 17292
- Fire safe API 607, ISO 10497

Approvals

- PED 97/23/CE
- FIRE SAFE
- TA-LUFT
- ISO 15848
- ATEX (94/9/CE)
- TÜV AD 2000-Merkblatt A4
- SIL (ICE 61508)
- EN 161/264
- DVGW - EN 13774

DN 150-300 / PN 10-40

Standard construction materials

Description	Material	
	Carbon steel	Stainless steel
Body	1.0619	1.4408
Ball	1.4408	1.4408
Seats	PTFE	PTFE
Stem	1.4401	1.4401
Stem packing	PTFE + Graphite	PTFE + Graphite
Body seal 1	PTFE	PTFE
Body seal 2	Graphite	Graphite

Other materials, upon request.





Full trunnion split body

■ General features

- Full bore
- Soft seat
- Self cavity pressure relief
- Bidirectional
- Fire safe
- Anti blow out stem
- Autoadjustable packing
- Double block and bleed
- Antistatic stem
- Spring loaded seat system
- Low emission design

■ Standards

- Top flange ISO 5211
- Flanges EN 1092-1
- Face to face EN 558 serie 15 (former F5)
- Testing EN 12266, ISO 5208, API 598
- Material according NACE MR 0175
- Design EN 12516, ISO 17292
- Fire Safe API 607, ISO 10497

■ Approvals

- PED 97/23/CE
- FIRE SAFE
- TA-LUFT
- ISO 15848
- ATEX (94/9/CE)
- TÜV AD 2000-Merkblatt A4
- SIL (ICE 61508)

■ DN 150 - 300 / PN 10 - 40

■ Standard construction materials

Description	Material	
	Carbon steel	Stainless steel
Body	1.0619	1.4408
Ball	1.4408	1.4408
Seats	PTFE	PTFE
Stem	1.4462	1.4462
Stem packing	PTFE + Graphite	PTFE + Graphite
Body seal	PTFE	PTFE
Body seal 2	Graphite	Graphite

Other materials, upon request.





Full trunnion 3 pieces

General features

- Full and reduced bore
- Soft seat
- Self cavity pressure relief
- Bidirectional
- Fire safe
- Anti blow out stem
- Autoadjustable packing
- Double block and bleed
- Antistatic stem
- Spring loaded seat system
- Low emission design
- In line packing maintenance

Standards

- Top flange ISO 5211
- Flanges EN 1092-01
- Face to face EN 558 series 1, 2, 15 (Former F1, F2,F15)
- Testing EN 12266, ISO 5208
- Design EN 12516, ISO 17292
- Fire Safe API 607, ISO 10497

Approvals

- PED 97/23/CE
- FIRE SAFE
- TA-LUFT (up to DN300-PN100)
- ISO 15848 (up to DN300-PN100)
- ATEX (94/9/CE)
- SIL (ICE 61508)
- DVGW - EN 13774

- DN 50 - 300 / PN 400
- DN 50 - 400 / PN 250
- DN 50 - 500 / PN 160
- DN 50 - 600 / PN 16 - 100

Standard construction materials

Description	Material	
	Carbon steel	Stainless steel
Body	1.0460	1.4401
Ball	1.4408	1.4408
Seats	PTFE + CG	PTFE + CG
Stem	1.4462	1.4462
Stem packing	Viton + Graphite	Viton + Graphite
Body seal 1	PTFE + CG	PTFE + CG
Body seal 2	Graphite	Graphite

Other materials, upon request.



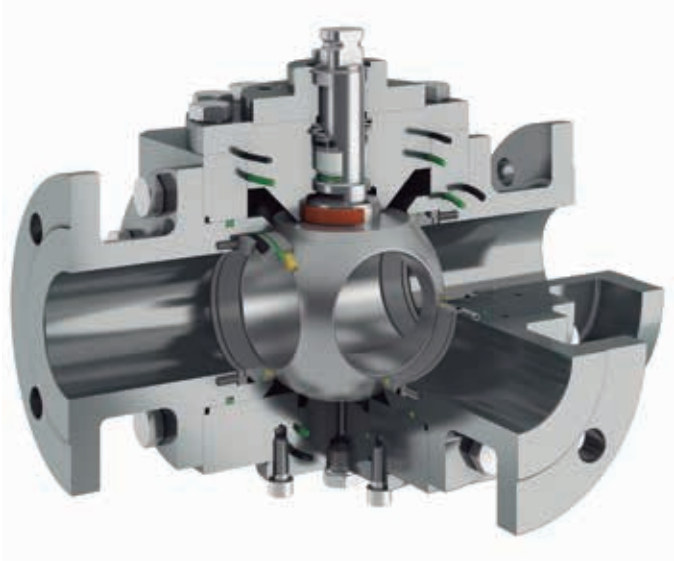

Three & four way

■ General features

- Floating and guided ball
- Full bore
- Soft seat
- L,T or X bore
- Antistatic stem
- Anti blow out stem
- Autoadjustable packing
- Four seats
- Self cavity pressure relief

■ Standards

- Top flange ISO 5211
- Flanges EN 1092-01
- Face to face standard Pekos
- Testing EN -12266, ISO 5208
- Design EN -12516, ISO 17292

■ Approvals

- PED 97/23/CE
- TA-LUFT
- ISO 15848
- ATEX (94/9/CE)
- SIL (ICE 61508)

■ DN 15-300 / PN 10-40

■ Standard construction materials

Description	Material	
	Carbon steel	Stainless steel
Body	1.0619	1.4408
Ball	1.4408	1.4408
Seats	PTFE	PTFE
Stem	1.4401	1.4401
Stem packing	PTFE	PTFE
Body seal	PTFE	PTFE

Other materials, upon request.





Wafer

General features

- Floating ball
- Full bore
- End entry
- Soft seat
- Bidirectional
- Fire safe
- Anti blow out stem
- Autoadjustable packing
- Self cavity pressure relief
- Antistatic stem

Standards

- Top flange ISO 5211
- Flanges EN 1092-01
- Testing EN 12266, ISO 5208
- Design EN 12516 , ISO 17292
- Fire safe API 607, ISO 10497

Approvals

- PED 97/23/CE
- TA-LUFT
- FIRE SAFE
- ATEX (94/9/CE)
- SIL (ICE 61508)

- DN 15 - 80 / PN 40
- DN 15 - 100 / PN 16

Standard construction materials

Description	Material	
	Carbon steel	Stainless steel
Body	1.0619	1.4408
Ball	1.4408	1.4408
Seats	PTFE	PTFE
Stem	1.4401	1.4401
Stem packing	Graphite	Graphite
Body seal 1	Graphite	Graphite
Body seal 2	Viton	viton

Other materials, upon request.





Tank bottom

■ General features

- Full bore
- Soft seat
- Anti blow out stem
- Inclined stem
- Autoadjustable packing
- End entry
- Antistatic stem

■ Standards

- Top flange ISO 5211
- Flanges EN 1092-01
- Testing EN 12266, ISO 5208
- Design EN 12516, ISO 17292, DIN 28140-1 (PN 10)

■ Approvals

- PED 97/23/CE
- TA-LUFT
- ISO 15848
- ATEX (94/9/CE)
- TÜV AD - Merkblatt A4
- SIL (ICE 61508)

■ DN 40 - 100 / PN 16

■ DN 40 - 250 / PN 10

■ Standard construction materials

Description	Material
	Stainless steel
Body	1.4408
Ball	1.4408
Seats	PTFE + FG
Stem	1.4401
Stem packing	PTFE + FG / Viton
Body seal 1	PTFE+ FG
Body seal 2	Viton

Other materials, upon request.





Cryogenic valve

General features

- Split body / full trunnion
- Floating and guided ball
- Full bore
- Soft seat
- Spring leaded seat system
- Anti blow out stem
- Autoadjustable packing
- Self cavity pressure relief
- Antistatic stem
- Service Temp. to -196°
- Fire safe

Standards

- Top flange ISO 5211
- Flanges EN 1092-01
- Face to face - EN 558 series 1, 14, 15 (Former F1,F4,F5)
- Testing EN 12266, ISO 5208
- Design EN 12516, ISO 17292
- Fire safe API607, ISO 10497

Approvals

- PED 97/23/CE
- FIRE SAFE
- BS 6364
- ATEX (94/9/CE)
- SIL (ICE 61508)

FLOATING:

- DN 15 - 50 / PN 63 - 100
- DN 15 - 125 / PN 25 - 40
- DN 15 - 200 / PN 10 -16

TRUNNION:

- DN 40 - 600 / PN 10 -100

Standard construction materials

Description	Material
	Stainless steel
Body	1.4408 / 1.4401
Ball	1.4408
Seats	Kelf
Stem	XM-19
Stem packing	Graphite + PTFE
Body seal 1	PTFE
Body seal 2	Graphite

Other materials, upon request.



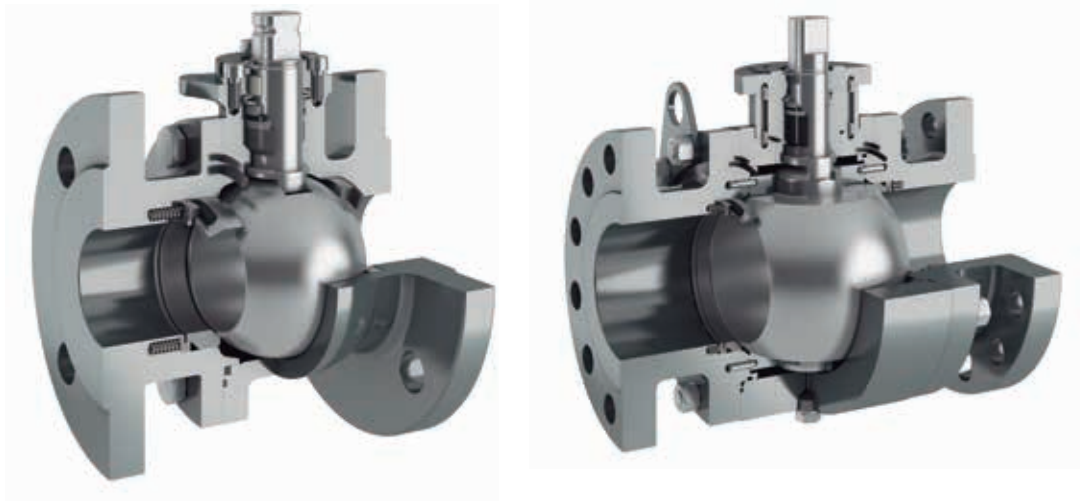

Metal seated

General features

- Split body/Full trunnion
- Floating and guided ball
- Full Bore
- Bidirectional
- Antistatic stem
- Anti blow out stem
- Autoadjustable packing
- Self cavity pressure relief
- Fire safe
- Spring loaded seat system

Standards

- Top flange ISO 5211
- Flange EN 1092-01
- Face to face EN 558 series 1, 2, 14, 15 (Former F1, F2, F4, F5)
- Testing EN 12266, ISO 5208, API 598
- Design EN 12516, ISO 17292
- Fire safe API 607, ISO 10497

Approvals

- PED 97/23/CE
- FIRE SAFE
- TA-LUFT (up to DN300-PN100)
- ISO 15848 (up to DN300-PN100)
- ATEX (94/9/CE)
- SIL (ICE 61508)

- DN 50 - 300 / PN 400
- DN 50 - 400 / PN 250
- DN 50 - 500 / PN 160
- DN 50 - 600 / PN 16 - 100

Standard construction materials

Description	Material	
	Carbon steel	Stainless steel
Body	1.0619 / 1.0352	1.4408 / 1.4401
Ball	1.4408+Cr Carbide	1.4408+Cr Carbide
Seats	1.4401+Cr Carbide	1.4401+Cr Carbide
Stem	1.4401 / XM-19	1.4401 / XM-19
Stem packing	Graphite	Graphite
Body seal 1	Graphite	Graphite
Body seal 2	Graphite	Graphite

Other materials, upon request.

General valve design

Floating

Guided

Trunnion

Body construction

Split body

Three pieces

End entry

Official approvals

FIRE SAFE

ATEX

TA-Luft and ISO 15848

CE marking (PED 97/23/EC)

API 6D

IEC 61508 SIL3 Capable

DVGW-EN 13774

EN161 & EN13774 (EN264)

Stem:

ISO 5211

Auto adjusting packing / Maintenance free

Fire safe device

Anti-blow out

Antistatic stem

Locking device

Seats design:

Standard soft seat

Spring loaded seat (Soft or Metal)

Simple Piston Effect [SPE]

Double Piston Effect [DPE]

Protected seat

Primary Metal Secondary Soft [PMSS]

Cavity relief

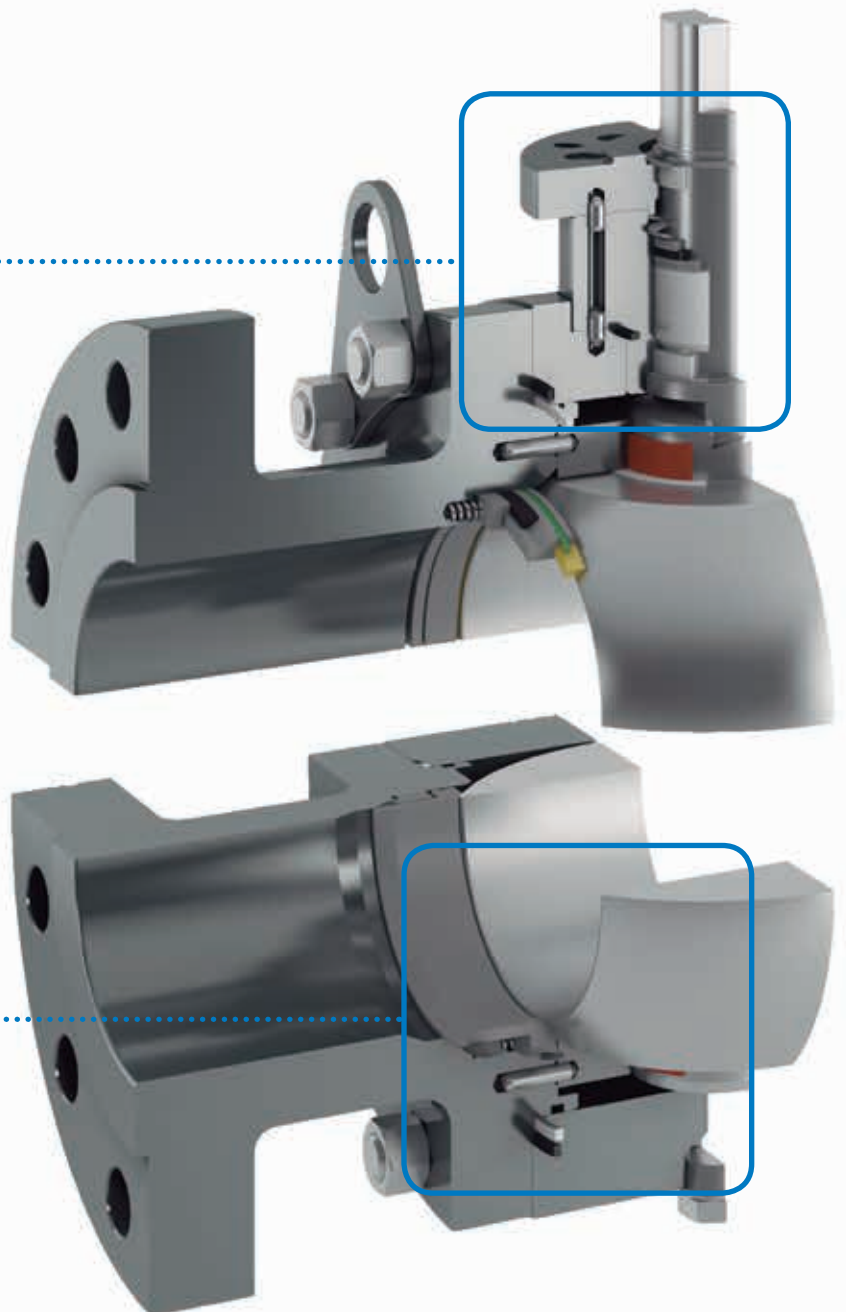

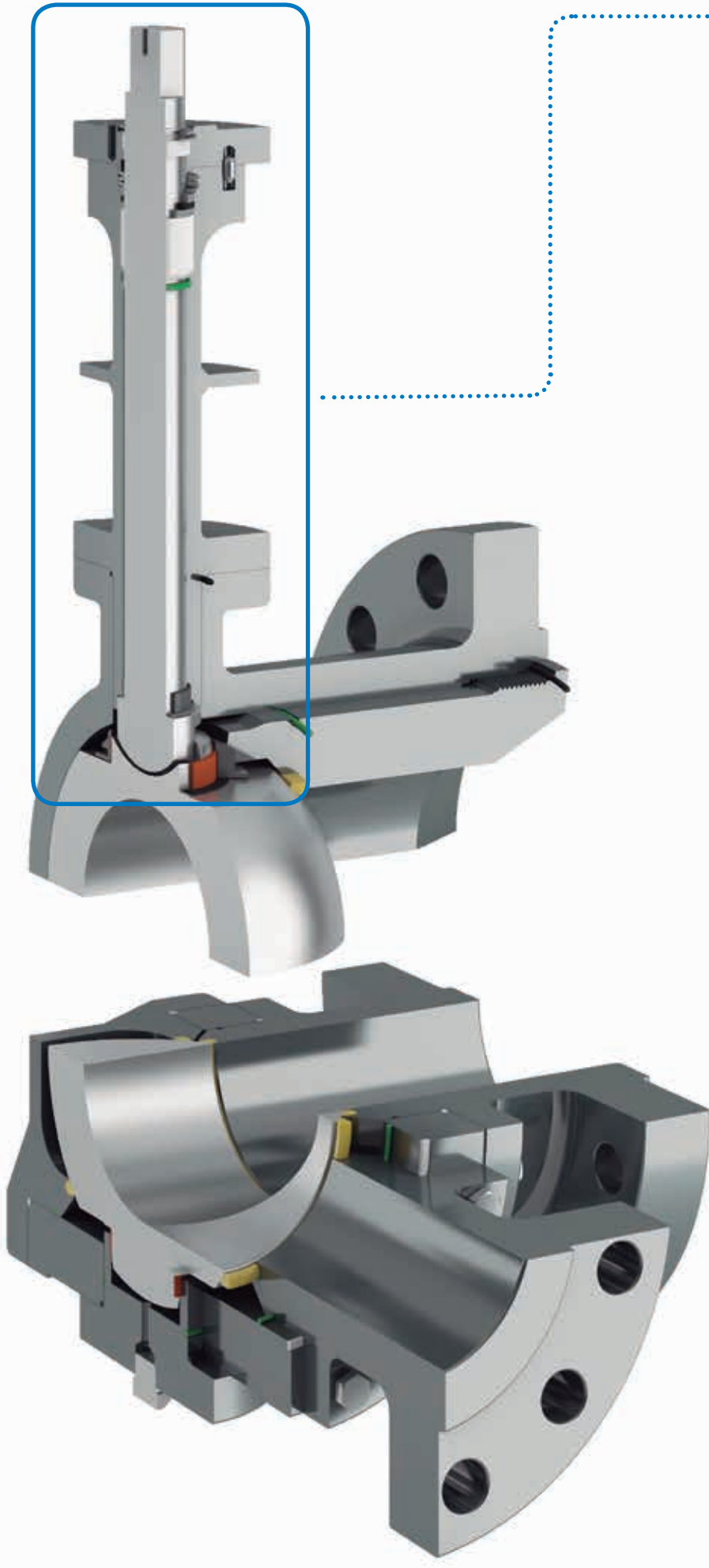

Stem extension:

Different types

Simple

Standard

Security

Cryogenic

Available options

Double packing system

Fugitive emission detector

Welded

Range of products:

2,3 or 4 way (Full or Reduce Bore)

Soft seat

Metal seat

Cryogenic

Tank Bottom

Wafer

Available options upon request:

Cavity filler

Cleaned and Degreased

Pigging

Unidirectional

V-Port for control

Heating jacket

Seat sealant injection

Stem sealant injection

Sampling



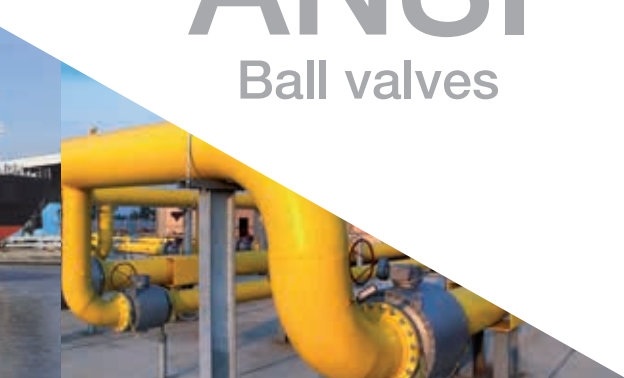

ANSI

Ball valves





Floating ball

General features

- Split body
- Full Bore
- Soft seat
- Bidirectional
- Antistatic stem
- Anti blow out stem
- Autoadjustable packing
- Self cavity pressure relief
- Fire safe
- Low emission design

Standards

- Top flange ISO 5211
- Flanges ANSI 16.5
- Material according NACE MR 0175
- Face to face ANSI 16.10
- Testing ISO 5208, API 598
- Design ANSI B16.34, ISO 17292, API 6D
- Fire safe API 607, ISO 10497

Approvals

- PED 97/23/CE
- FIRE SAFE
- TA-LUFT
- ISO 15848
- ATEX (94/9/CE)
- API 6D
- SIL (ICE 61508)
- EN 161/264

- 1/2" - 2" / Class 600
- 1/2" - 4" / Class 300
- 1/2" - 8" / Class 150

Standard construction materials

Description	Material	
	Carbon steel	Stainless steel
Body	A 216 WCC	A351 CF8M
Ball	A351 CF8M	A351 CF8M
Seats	PTFE	PTFE
Stem	AISI 316	AISI 316
Stem packing	PTFE + Graphite	PTFE + Graphite
Body seal 1	PTFE	PTFE
Body seal 2	Graphite	Graphite

Other materials, upon request.





Guided ball

General features

- Split body
- Full bore
- Soft seat
- Bidirectional
- Antistatic stem
- Anti blow out stem
- Autoadjustable packing
- Self cavity pressure relief
- Fire safe
- Low emission design

Standards

- Top flange ISO 5211
- Flanges ANSI 16.5
- Face to face ANSI 16.10
- Material according NACE MR 0175
- Testing ISO 5208, API 598
- Design ANSI B16.34, ISO 17292, API 6D
- Fire safe API 607, ISO 10497

Approvals

- PED 97/23/CE
- FIRE SAFE
- TA-LUFT
- ISO 15848
- ATEX (94/9/CE)
- API 6D
- SIL (ICE 61508)
- EN 161/264

6" - 12" / Class 150 - 300

Standard construction materials

Description	Material	
	Carbon steel	Stainless steel
Body	A 216 WCC	A351 CF8M
Ball	A351 CF8M	A351 CF8M
Seats	PTFE	PTFE
Stem	AISI 316	AISI 316
Stem packing	PTFE + Graphite	PTFE + Graphite
Body seal 1	PTFE	PTFE
Body seal 2	Graphite	Graphite

Other materials, upon request.





Side entry

General features

- Floating ball
- One piece body
- Reduced bore
- Soft seat
- Bidirectional
- Antistatic stem
- Anti blow out stem
- Autoadjustable packing
- Self cavity pressure relief
- Fire safe
- Low emission design

Standards

- Top flange ISO 5211
- Flanges ANSI 16.5
- Face to face ANSI 16.10
- Material according NACE MR 0175
- Testing ISO 5208, API 598
- Design ANSI B16.34, ISO 17292, API 6D
- Fire safe API 607, ISO 10497

Approvals

- PED 97/23/CE
- FIRE SAFE
- TA-LUFT
- ISO 15848
- ATEX (94/9/CE)
- API 6D
- SIL (ICE 61508)

■ 1/2" - 8" / Class 300

■ 1/2" - 12" / Class 150

Standard construction materials

Description	Material	
	Carbon steel	Stainless steel
Body	A 216 WCC	A351 CF8M
Ball	A351 CF8M	A351 CF8M
Seats	PTFE	PTFE
Stem	AISI 316	AISI 316
Stem packing	PTFE + Graphite	PTFE + Graphite
Body seal 1	Graphite	Graphite
Body seal 2	Viton	Viton

Other materials, upon request.





Three pieces forged

General features

- Floating ball
- Full and Reduced Bore
- Soft seat
- Bidirectional
- Antistatic stem
- Anti blow out stem
- Autoadjustable packing
- Self cavity pressure relief
- Fire safe
- In line packing maintenance

Standards

- Top flange ISO 5211
- Testing EN 12266, ISO 5208, API 598
- Design ANSI B16.34, API 6D
- Material according NACE MR 0175
- Fire safe API 607, ISO 10497

Approvals

- PED 97/23/CE
- FIRE SAFE
- ATEX (94/9/CE)
- API 6D
- SIL (ICE 61508)

- 1/4" - 1" / Class 2500
- 1/4" - 2" / Class 1500-900
- 1/4" - 1 1/2" / Class 800
- 2" - 2 1/2" / Class 600
- 3" / Class 400

Standard construction materials

Description	Material	
	Carbon steel	Stainless steel
Body	A 105/LF2	A 182 F316/316L
Ball	AISI 316/316L	AISI 316/316L
Seats	PTFE +CG	PTFE +CG
Stem	AISI 316/316L	AISI 316 /316L
Stem packing	Graphite	Graphite
Body seal 1	PTFE +CG	PTFE+CG
Body seal 2	Graphite	Graphite

Other materials, upon request.

End connections

- Screwed NPT, BSPP, BSPT
- Socket weld ANSI 16.11
- Butt weld ANSI 16.25
- Nipples P.E., BW
- Flanged ANSI 16.5





Full trunnion Split body

■ General features

- Full bore
- Soft seat
- Self cavity pressure relief
- Bidirectional
- Fire safe
- Anti blow out stem
- Autoadjustable packing
- Double block and bleed
- Antistatic stem
- Spring loaded seat system
- Low emission design

■ Standards

- Top flange ISO 5211
- Flanges ANSI 16.5
- Face to face ANSI 16.10
- Testing ISO 5208, API 598
- Material according NACE MR 0175
- Design ANSI B16.34, ISO 17292, API 6D
- Fire Safe API 607, ISO 10497

■ Approvals

- PED 97/23/CE
- FIRE SAFE
- TA-LUFT
- ISO 15848
- ATEX (94/9/CE)
- API 6D
- SIL (ICE 61508)
- EN 161/264

■ 2" - 12" / Class 150-300

■ Standard construction materials

Description	Material	
	Carbon steel	Stainless steel
Body	A 216 WCC	A351 CF8M
Ball	A351 CF8M	A351 CF8M
Seats	PTFE	PTFE
Stem	A 182 F51	A 182 F51
Stem packing	PTFE+ Graphite	PTFE + Graphite
Body seal 1	PTFE	PTFE
Body seal 2	Graphite	Graphite

Other materials, upon request.



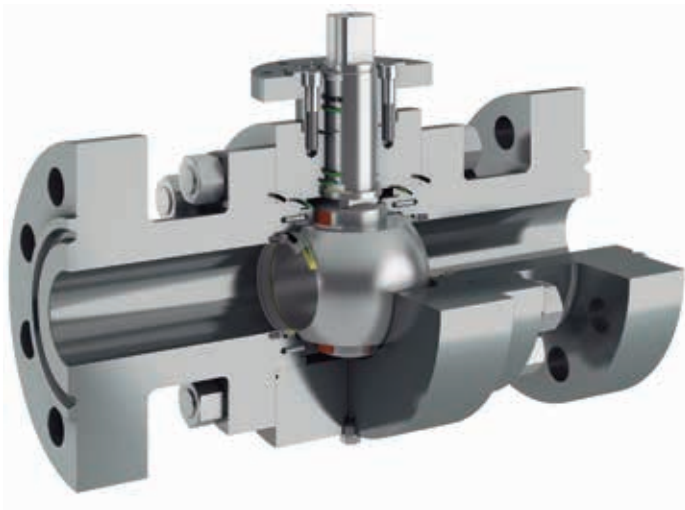

Full trunnion 3 pieces

General features

- Full and reduced bore
- Soft seat
- Self cavity pressure relief
- Bidirectional
- Fire safe
- Anti blow out stem
- Autoadjustable packing
- Double block and bleed
- Antistatic stem
- Spring loaded seat system
- Low emission design
- In line packing maintenance

Standards

- Top flange ISO 5211
- Face to face ANSI 16.10
- Testing ISO 5208, API 598
- Material according NACE MR 0175
- Design ANSI B16.34, ISO 17292, API 6D
- Fire Safe API 607, ISO 10497

Approvals

- PED 97/23/CE
- FIRE SAFE
- TA-LUFT (up to 12" CL600)
- ISO 15848 (up to 12" CL600)
- ATEX (94/9/CE)
- API 6D
- SIL (ICE 61508)

- 2" - 12" / Class 2500
- 2" - 16" / Class 1500
- 2" - 20" / Class 900
- 2" - 24" / Class 150 - 600

Standard construction materials

Description	Material	
	Carbon steel	Stainless steel
Body	A105/LF2	A 182 F316
Ball	A351 CF8M	A351 CF8M
Seats	PTFE	PTFE
Stem	A 182 F51	A 182 F51
Stem packing	PTFE + Graphite	PTFE + Graphite
Body seal	PTFE	PTFE

Other materials, upon request.

Ends connections

- Flanges RF, RTJ ANSI 16.5
- Socket weld ANSI 16.11
- Butt weld ANSI 16.25



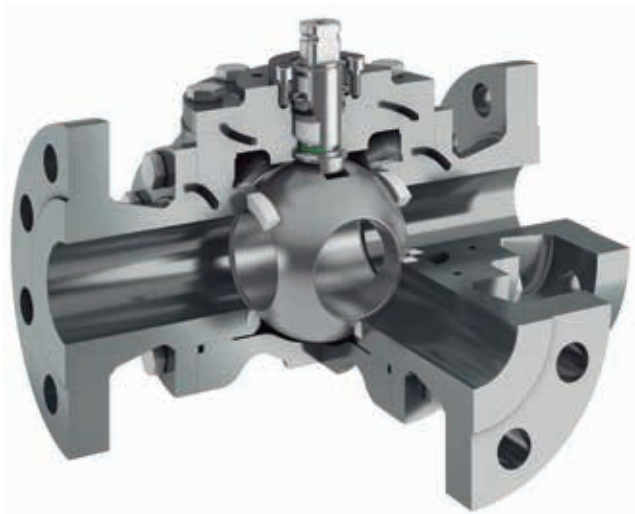

Three & four way

■ General features

- Floating and guided ball
- Full bore
- Soft seat
- L,T or X
- Antistatic stem
- Anti blow out stem
- Four seats
- Self cavity pressure relief
- Autoadjustable packing

■ Standards

- Top flange ISO 5211
- Flanges ANSI 16.5
- Face to face standard Pekos
- Material according NACE MR 0175
- Testing ISO 5208, API 598
- Design ANSI B16.34, ISO 17292, API 6D

■ Approvals

- PED 97/23/CE
- TA-LUFT
- ISO 15848
- ATEX (94/9/CE)
- API 6D
- SIL (ICE 61508)

■ 1/2"- 12" / Class 150-300

■ Standard construction materials

Description	Material	
	Carbon steel	Stainless steel
Body	A 216 WCC	A351 CF8M
Ball	A351 CF8M	A351 CF8M
Seats	PTFE	PTFE
Stem	AISI 316 / A182 F51	AISI 316 / A182 F51
Stem packing	PTFE + Graphite	PTFE + Graphite
Body seal	PTFE	PTFE

Other materials, upon request.





Wafer

General features

- Floating ball
- Full bore
- End entry
- Soft seat
- Bidirectional
- Fire safe
- Antistatic stem
- Anti blow out stem
- Autoadjustable packing
- Self cavity pressure relief

Standards

- Top flange ISO 5211
- Flanges ANSI 16.5
- Testing ISO 5208, API 598
- Material according NACE MR 0175
- Design API 6D, ANSI B16.34
- Fire safe API 607, ISO 10497

Approvals

- PED 97/23/CE
- TA-LUFT
- FIRE SAFE
- ATEX (94/9/CE)
- API 6D
- SIL (ICE 61508)

DN 1/2" - 4" / Class 150

Standard construction materials

Description	Material	
	Carbon steel	Stainless steel
Body	A216 WCC	AISI 316
Ball	A351 CF8M	A351 CF8M
Seats	PTFE	PTFE
Stem	AISI 316	AISI 316
Stem packing	Graphite	Graphite
Body seal 1	Graphite	Graphite
Body seal 2	Viton	viton

Other materials, upon request.





Cryogenic valve

General features

- Split body full trunnion
- Floating and guided ball
- Full bore
- Soft seat
- Spring seat system
- Degreased
- Anti blow out stem
- Autoadjustable packing
- Self cavity pressure relief
- Antistatic stem
- Service Temp. to -196°
- Fire safe

Standards

- Top flange ISO 5211
- Flanges ANSI 16.5
- Face to face B16.10
- Materials according NACE MR 0175
- Testing BS 6364, API 598
- Design ANSI B16.34, ISO 17292, API 6D
- Fire safe API 607, ISO 10497

Approvals

- PED 97/23/CE
- FIRE SAFE
- ATEX (94/9/CE)
- API 6D
- SIL (ICE 61508)
- BS 6364

FLOATING:

- 1/2" - 2" / Class 600
- 1/2" - 4" / Class 300
- 1/2" - 8" / Class 150

TRUNNION:

- 1 1/2" - 24" / Class 150-600

Standard construction materials

Description	Material
	Stainless steel
Body	A351 CF8M / A 182 F316
Ball	A351 CF8M
Seats	Kelf
Stem	XM-19
Stem packing	Graphite + PTFE
Body seal 1	PTFE
Body seal 2	Graphite

Other materials, upon request.



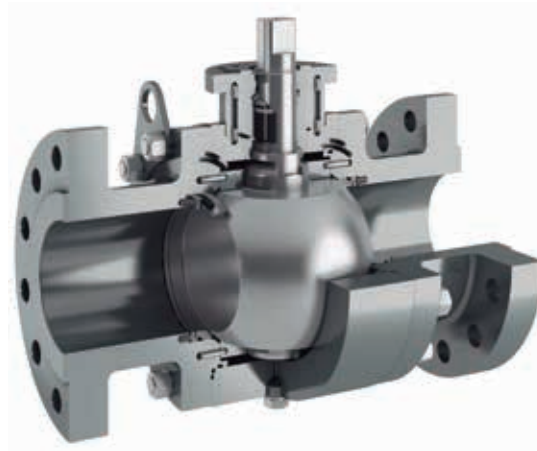
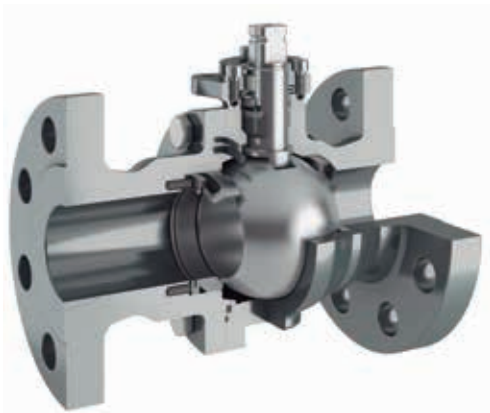

Metal seated

General features

- Split body/Full trunnion
- Floating and guided ball
- Full Bore
- Bidirectional
- Anti blow out stem
- Autoadjustable packing
- Self cavity pressure relief
- Antistatic stem
- Fire safe
- Spring leaded seat system

Standards

- Top flange ISO 5211
- Flanges ANSI B16.5
- Face to face ANSI B16.10
- Material according NACE MR 0175
- Testing ISO 5208, API 598
- Design ANSI B16.34, ISO 17292, API 6D
- Fire safe API 607, ISO 10497

Approvals

- PED 97/23/CE
- FIRE SAFE
- TA-LUFT (up to 12" CL600)
- ISO 15848 (up to 12" CL600)
- ATEX (94/9/CE)
- API 6D
- SIL (ICE 61508)

- 1/2" - 12" / Class 2500
- 1/2" - 16" / Class 1500
- 1/2" - 20" / Class 900
- 1/2" - 24" / Class 150 - 600

Standard construction materials

Description	Material	
	Carbon steel	Stainless steel
Body	A105/A216 WCC	A351 CF8M
Ball	A351 CF8M+Cr Carbide	A351 CF8M +Cr Carbide
Seats	A351 CF8M+Cr Carbide	A351 CF8M +Cr Carbide
Stem	AISI 316 / XM-19	AISI 316 / XM-19
Stem packing	Graphite	Graphite
Body seal1	Graphite	Graphite
Body seal2	Graphite	Graphite

Other materials, upon request.



Approvals, certificates and quality control

All Pekos valves are designed, produced and certified by the most widely accepted international standards. Our total quality control system is designed to assure that every step from material procurement through machining, assembly, testing and packaging meet our main goal - Always exceeding the expectations of our customers.



Pekos is supplying to more than 90 countries around the globe since 1988. This wide acceptance is testimony to the company's ability to understand and efficiently respond to the requirements of current global market.



Main end users



AIR LIQUIDE	CLARIANT	LUKOIL	SABIC
AKZO	GRAY VALLEY	OMV	SASOL
ALROSA	DSM RESINS	PDO	SHELL
ALSTOM	EGYPT GAS	PETROBAS	SOLVAY
BASF	ENI	PETROM	SONALGAZ
BOREALIS	GDF	PROCTER & GAMBLE	SONATRACH
BOROUGE	GENERAL ELECTRIC	QAPCO	STATOIL
BP	ICI	QATAR PETROLEUM	TOTAL
BP EXPLORATION	KAO	REPSOL	TÜPRAS
CEPSA	KEMIRA	ROCH	
CIBA GEIGY	KUWAIT OIL	ROMGAZ	



www.pekos.es

Rec del Molinar, 9 - P.I. El Circuit
08160 Montmeló (Barcelona) - Spain

Tel.: (+34) 93 568 92 56

pekos@pekos.es