

Richter Chemical Peripheral Pumps with Magnetic Drive

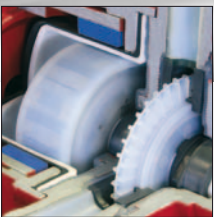

High efficiency and long service life thanks to resilient impeller sealing lips

Materials: PFA/PTFE, SSiC

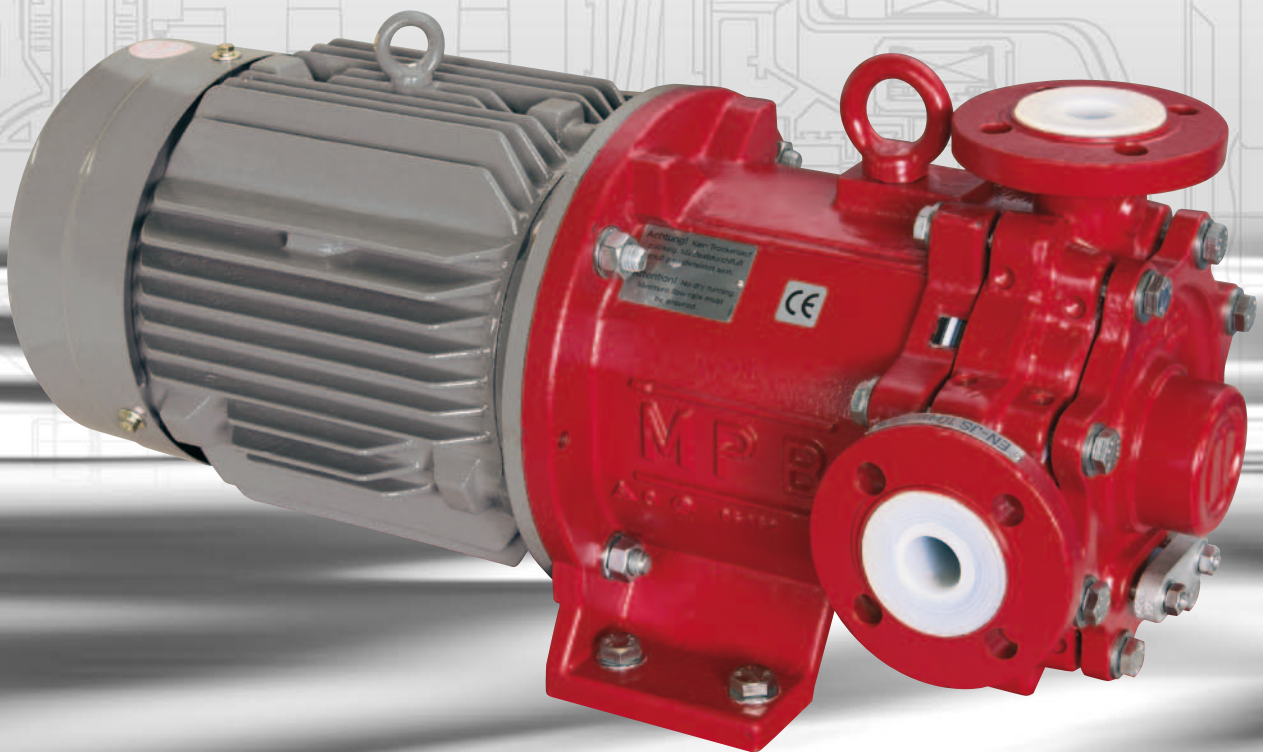

RICHTER
Process Pumps & Valves

INDEX
FLUID & METERING

Robust, reliable, maintenance-orientated: The Richter peripheral pump MPB

Range of application:

The design of a peripheral pump is specially tailored to the delivery of low flow rates at high delivery heads: a range not economically covered by standard centrifugal pumps.

The Richter MPB delivers 0.1-6 m³/h (0.4-26 USgpm) and achieves heads of up to 100 m (330 ft LC). It is hermetically sealed and has a magnetic coupling power of 6 kW/8 hp (at 2900 rpm). 3500 rpm on request.

Operating range: from -60 to +150 °C (-75 to +300 °F)* and from standstill vacuum up to 16 bar (235 psi), depending on the respective operating conditions and the pump accessories.

Further technical features:

- Compact close-coupled design, fast installation
- Robust design to meet the requirements of the chemical industry:
 - armouring of ductile cast iron ASTM A395 (EN-JS 1049)
 - metallic core of the shaft and the inner magnet assembly (no brittle ceramic).
 - thick-wall virgin PFA lining on wetted side
- Self-priming up to approx. 6 m/20 ft (water 20 °C/68 °F) with suitably designed suction and discharge lines, counterpressure on discharge side admissible up to approx. 0.2 bar (2.9 psi). Consult factory in case of self-priming operation.
- Symmetrical design of the flow-related components, thus no axial forces occur.
- Forced circulation ensures lubrication of both plain bearing pairs
- Radial rubbing safety ring at the lantern and the drive magnet assembly protects the can against damage by a possibly tumbling drive magnet assembly in the event of a defective motor shaft.
- Parts largely interchangeable with the magnetic drive centrifugal pumps MNK/MNK-B 25-25-125 and 50-32-125 owing to identical plain bearings, inner magnet assembly and can system.

* Observe local rules for the application of ductile cast iron at low temperatures.

Universally corrosion-resistant. Handles up to 30 % entrained gas.

The problems of impeller sealing with common lined peripheral pumps have been avoided:

- **Designed for a high degree of efficiency**, the integrated impeller sealing lips (patented) produce an unrivalled quality of sealing between the PFA-lined impeller and the SSiC silicon carbide ring channel wall. The highly-polished sliding surfaces of the ring channel provide **low friction and low wear** of the sealing lips.
- A further decisive advantage: **Simple and fast assembly** as the resilient sealing lips dispense with the adjustment of the impeller ring channel to an accuracy of 0.1 mm (0.004").

Such close, but hydraulically important gaps frequently result in premature wear in conventional peripheral pumps (particularly with fluctuating temperatures) and require a lot of time to achieve precise assembly and maintenance. However, the sealing lips of the MPB impeller **compensate for dimensional changes caused by thermal fluctuations**.

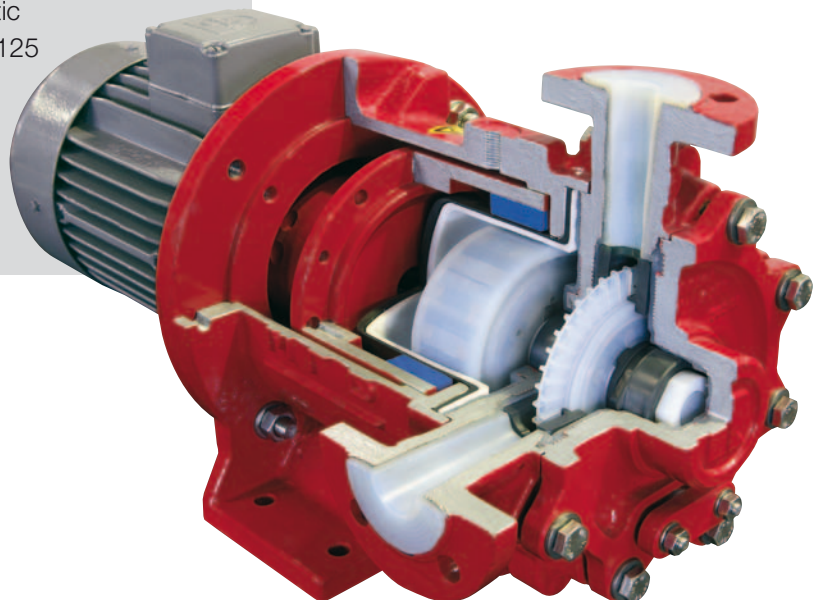

① **Housing and cover**

Ductile cast iron ASTM A395 (EN-JS 1049) with **thick-walled virgin and unfilled PFA-lining**

② **Static labyrinth seal**

and a virtually metallic contact for **permanent tightness and dimensional accuracy**

③ **Ring channel of pure SSiC silicon carbide**

extremely corrosion-resistance, inherently stable, abrasion-resistant

④ **PFA-lined stainless steel impeller**

Resilient sealing lips on both sides (patented):

- No axial gap adjustment, thus **fast and trouble-free pump assembly**
- **Compensate for operation-related dimensional changes, e.g. due to fluctuating temperatures**
- Provide a **low-friction sliding seal with dynamic contact pressure**

⑤ **Eddy-current-free double can**

- Inner can of PTFE
- Outer can of carbon-fibre-reinforced plastic (CFRP)
- Can monitoring on request

⑥ **Magnetic coupling power**

of 6 kW (8 hp) at 2900 rpm. High-performance permanent magnets. 3500 rpm on request.

⑦ **SSiC bearing sleeves arranged on both sides of the impeller,**

optional **dry-run optimized SAFEGLIDE® PLUS** version

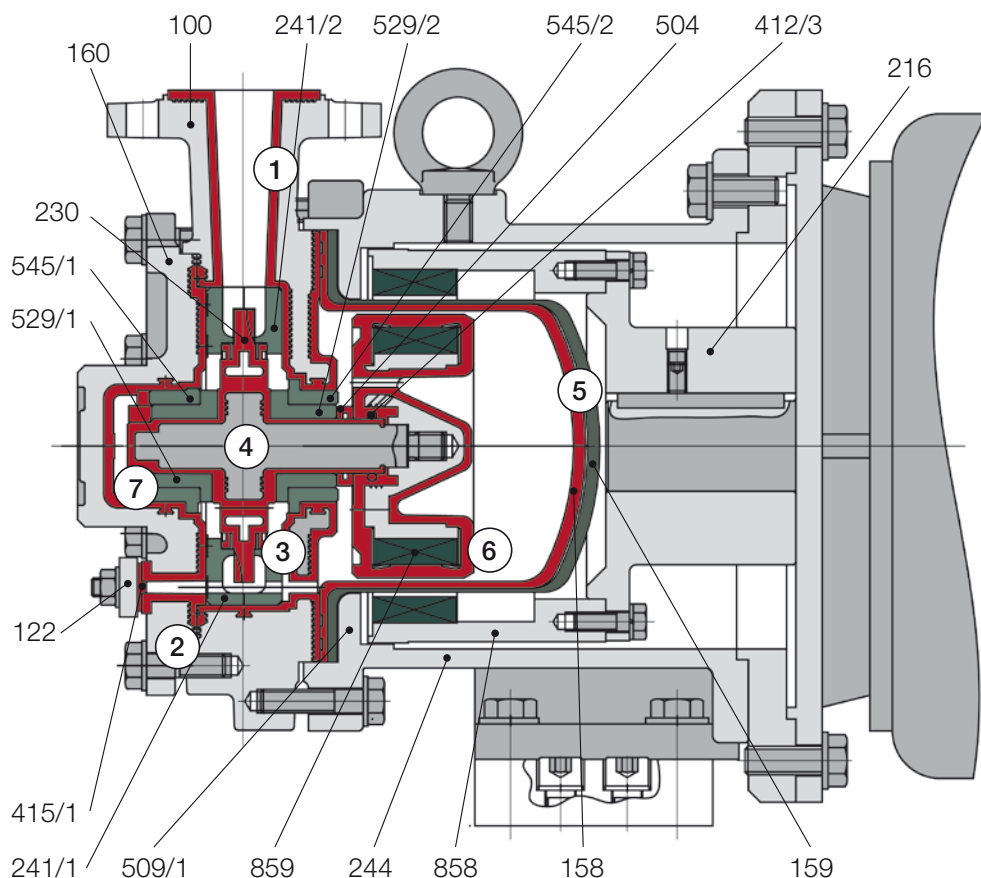

Components and materials

Item	Designation	Material
100	Casing (housing)	Ductile cast iron ASTM A395 (EN-JS 1049)/PFA
122*	Blind cover	Steel
158	Containment shell insert	PTFE
159	Can	CFRP (carbon-fiber reinforced plastic)
160	Cover	Ductile cast iron ASTM A395 (EN-JS 1049)/PFA
216	Hollow drive shaft	Steel
230	Impeller	PFA
241/x	Ring channel, 2-piece	SSiC
244	Lantern	Ductile cast iron ASTM A395 (EN-JS 1049)
412/3	O-ring	Kalrez® or equivalent
415/x*	Centering gasket	PTFE
504	Distance ring	PTFE
509/1	Intermediate ring	PTFE
529/x	Bearing sleeve	SSiC or optional SSiC SAFEGLIDE® PLUS dry-run optimized
545/x	Bearing bush	SSiC or optional SSiC SAFEGLIDE® PLUS dry-run optimized
560	Stud	PTFE
858	Drive magnet assembly	Steel 1.0306/PFA, magnets NdFeB**
859	Inner magnet assembly	Steel 1.0601/PFA, magnets SmCo**

* Standard casing (housing) drain undrilled

** NdFeB = neodymium iron boron, SmCo = samarium cobalt

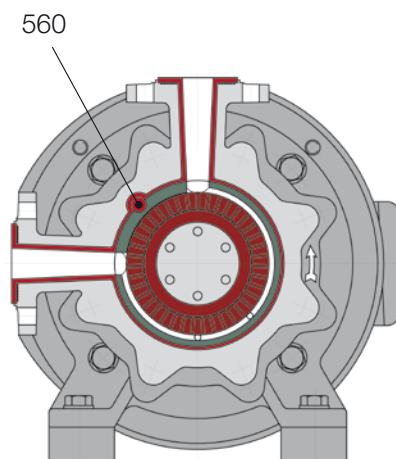

Front view: Section through the flow chamber
Nozzle position „┘“ or „┙“

Flow rates: 0.1-6 m³/h (0.4-26 USgpm), max. 100 m (330 ft LC). Dimensions: compact, fast installation.

Pump dimensions mm (inch):

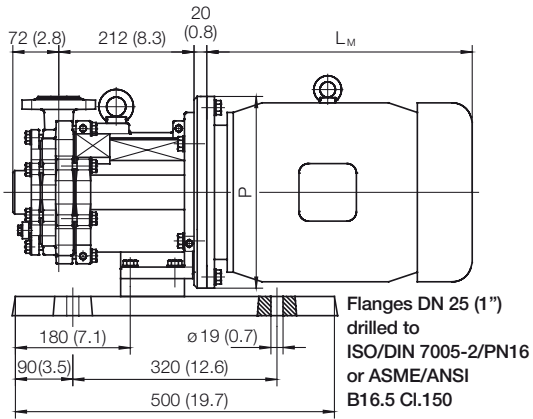

Nozzle position "┌"

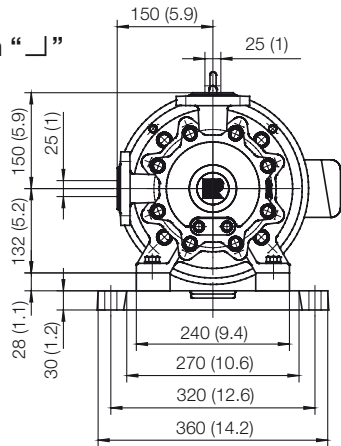

Nozzle position "└"

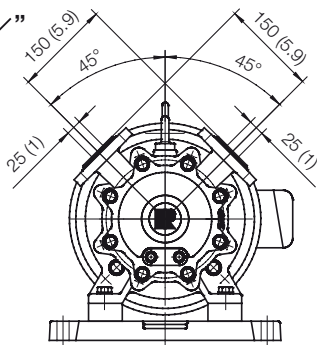

Presented by:

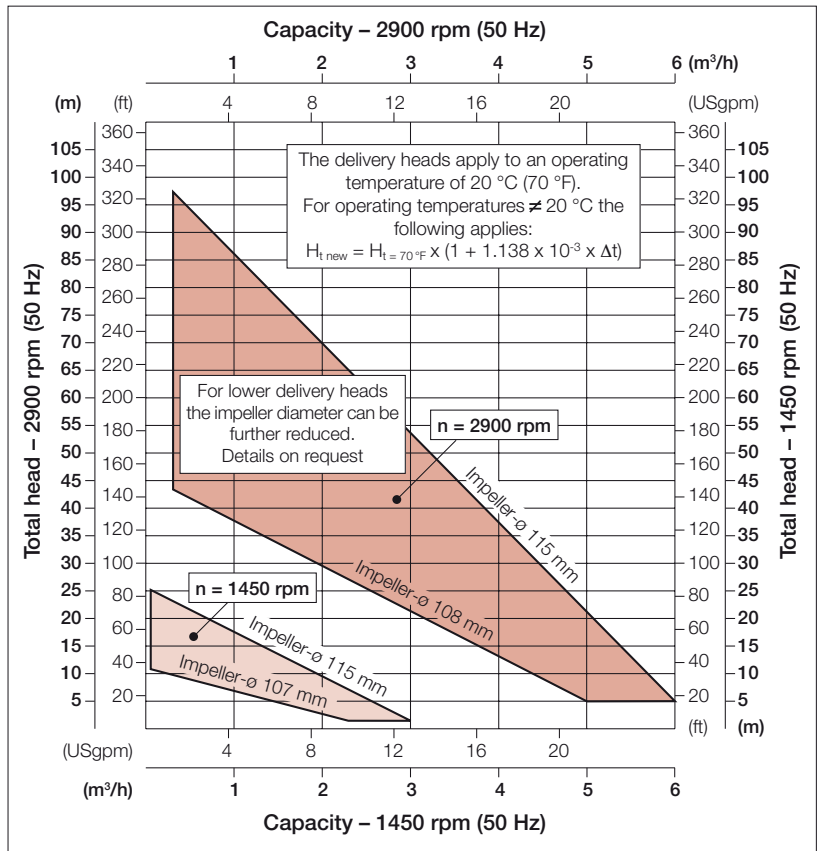
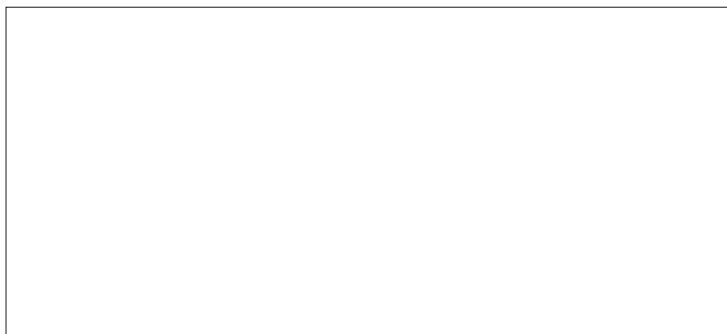

Kalrez®: Reg. TM DuPont
SAFEGLIDE® and Richter:
TM Richter Chemie-Technik GmbH



Richter Chemie-Technik GmbH
Otto-Schott-Str. 2, D-47906 Kempen, Germany
Tel. +49(0)21 52/146-0, Fax +49(0)21 52/146-190
www.richter-ct.com, richter-info@idexcorp.com